

SS-340-72P 72cells

320-340W

Management System

ISO 9001: Quality Management System

ISO 14001: Environmental Management System Standard

OHSAS 18001: International Occupational Health and Safety Assessment System Standard

Safety



Resistance to salt-spray corrosion (IEC61701, certified to TÜVRheinland test standard)



Resistance to ammonia Corrosion (IEC62716, certified to TÜVRheinland test standard)



Fire safety (Class C, certified to TÜVRheinland and Rheinland test standards)

Product Guarantee

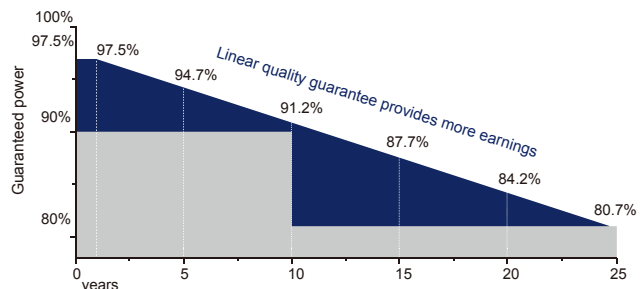

12 years Product quality & process guarantee

25 years Linear power guarantee

Reliability



Resistance to power attenuation passed TÜVRheinland system voltage endurance test



Product Certification



High performance



Excellent power output of modules in low light environment



100% double EL test enabling remarkable reduction of hidden crack rate of modules

Product Insurance



Specifications are subject to change without prior notice

SS-340-72P 72cells

Electric characteristics

Model of modules	SS-320-72P		SS-325-72P		SS-330-72P		SS-335-72P		SS-340-72P	
	STC	NOCT	STC	NOCT	STC	NOCT	STC	NOCT	STC	NOCT
Maximum power— P_{mp} (W)	320W	237W	325W	241W	330W	245W	335W	249W	340W	253W
Open-circuit voltage— V_{oc} (V)	46.4V	43.0V	46.7V	43.3V	46.9V	43.6V	47.2V	43.8V	47.5V	44.0V
Short-circuit current— I_{sc} (A)	9.05A	7.35A	9.10A	7.40A	9.14A	7.45A	9.18A	7.52A	9.22A	7.98A
Maximum power voltage— V_{mp} (V)	37.4V	34.7V	37.6V	35.0V	37.8V	35.3V	38.0V	35.6V	38.2V	35.9V
Maximum power current— I_{mp} (A)	8.56A	6.83A	8.66A	6.89A	8.74A	6.94A	8.82A	6.99A	8.91A	7.05A
Module efficiency— η_m (%)	16.49%		16.75%		17.01%		17.26%		17.52%	

STC : Irradiance 1000 W/m², 25°C, AM1.5

NOCT: Irradiance 800 W/m², 20°C, wind velocity 1m/s

Power tolerance (W)	(0,+3)
Maximum system voltage (V)	1000V/1500V
Maximum rated fuse current (A)	20

Electrical Performance & Temperature Dependence

Current-Voltage & Power-Voltage Curves (325W)

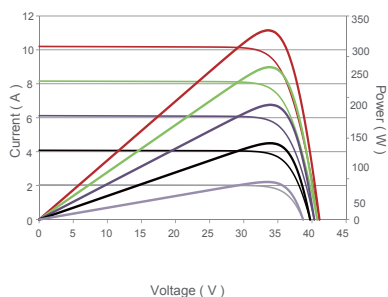

Temperature Dependence of I_{sc} , V_{oc} , P_{max}

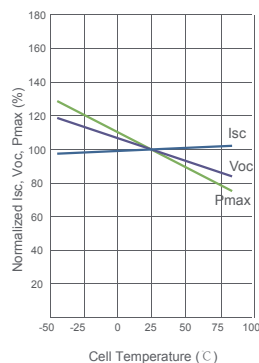

Engineering Drawings

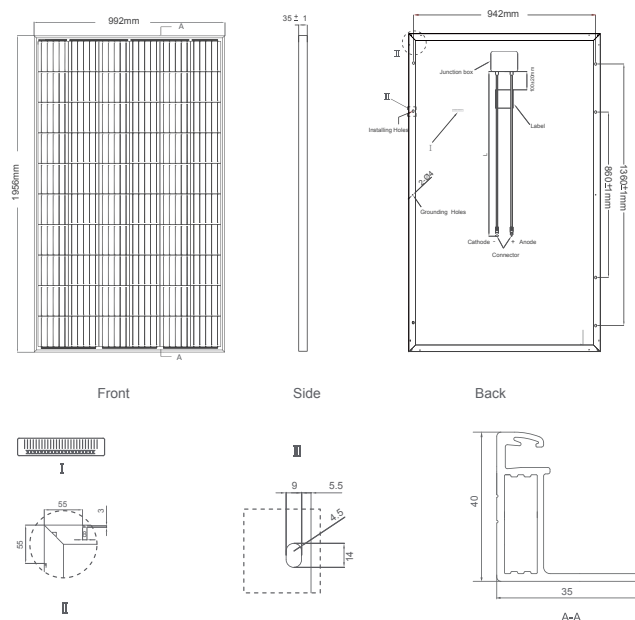

Temperature characteristics

Temperature coefficient at maximum power	-0.38 %/°C
Temperature coefficient of V_{oc}	-0.31 %/°C
Temperature coefficient of I_{sc}	+0.06 %/°C
current Operating temperature	-40~+85 °C
Rated operating temperature of cells	45±2 °C

Packaging Configuration

Container	20GP	40HC
Quantity/pallet	27	27
Pallets/container	10	22
Quantity/container	270	660

Structural characteristics

Module dimensions	1956 x 992 x 40 mm
Weight	22.5 kg
Cell	Polycrystal 156.75×156.75mm
Glass	3.2mm AR tempered
Frame	Anodized aluminum alloy
Junction box	IP67
Output wire	4.0 mm ² , wire length: 1200mm or Customized Length
Connector	MC4 compatible
Mechanical load	5400 Pa

Specifications are subject to change without prior notice